

Fidelity Components Electrolytecapacitors Power Supply



The series **MLytic® HC** and **MLytic® HC+** **High Current Power Cap** offer ultra-low ESR and ESL, due to a patented internal connection technique.

These capacitors, which were originally developed for use in locomotives, are consequently optimized for audio purposes and designed for heatsink mounting.

They can handle hundreds of amperes and supply extreme pulse currents. That is why even massive bass attacks are performed absolutely authentic and punchy.

Additionally their exceptional fastness results in most dynamic and accurate low frequency as well as a revealing and vivid mid and high frequency reproduction.

Whenever a power capacitor is needed for a first class transistor amplifier, the **MLytic® HC+** is first choice due to its superior 4-Pole Technology, as described on page 27.



Casing	D [mm]	l.o.a [mm]	Dimensions [mm]						
			a	b	h	s1	s2	x	
1	50	71	22.0	4	20	63	75	4.5	
2	75	70	31.7	4	20	90	102	4.5	
3	90	75	31.7	6	20	106	118	4.5	
4	90	104	31.7	6	20	106	118	4.5	

MLHC High Current Power Cap, Screw-Terminal, 2Pin

Rated Voltage [VDC]	Capacitance [µF] ±20%	Case Size Ø * L [mm]	Wire Size Ø * L [mm]	Rated Ripple Current IR~ at Tmax and 100Hz [A]	Surge Voltage [VDC]	ESR at 100 Hz [mOhm]	Tan δ @ 100Hz	Nominal Current IR for 5 Min. [µA]
80	10000	1	M5 (2Nm)	8,1	92	11	7	4800
80	22000	2	M5 (2Nm)	11,5	92	7	10	10560
80	47000	3	M6 (3Nm)	20,2	92	3	10	22560
100	22000	3	M6 (3Nm)	13,2	115	7	10	13200
100	33000	3	M6 (3Nm)	15,7	115	5	10	13200
100	47000	4	M6 (3Nm)	20,2	115	3	10	28200

MLHC+ High Current Power Cap, Screw-Terminal, 4Pin

Rated Voltage [VDC]	Capacitance [µF] ±20%	Case Size Ø * L [mm]	Wire Size Ø * L [mm]	Rated Ripple Current IR~ at Tmax and 100Hz [A]	Surge Voltage [VDC]	ESR at 100 Hz [mOhm]	Tan δ @ 100Hz	Nominal Current IR for 5 Min. [µA]
100	22000	3	M6 (3Nm)	13,8	115	7	10	13500
100	33000	3	M6 (3Nm)	16,5	115	5	10	18700
100	47000	4	M6 (3Nm)	21,1	115	3	10	29000



The **MLytic[®] HC · High Current Power Cap** series offers all benefits of Mundorf's unique **MLytic[®]** technology as described in detail on page 16 plus the following features:

Supply availability	Typically immediately ex stock for all types listed on page 28 4-6 weeks for your individual combination of features · from 18pcs only
Versatile applicable	RoHS-compliant · lead free REACH compliant Finest UL-listed ingredients only Sectional specification DIN 41332 · IEC 60384-4 Climatic category IEC 60068 40/105/56
Indication of origin	Made in Germany with greatest care
Capacitance range	1 000µF to 220 000µF
DC voltage range	40 · 50 · 63 · 80 · 100 · 160 · 250 · 350 · 450
Temperaturbereich	-25°C/-13°F to 105°C/+220°F
Useful lifetime [U _R · I _R]	8 000 hours at +105°C/+220°F 16 000 hours at +85°C/+185°F
Nennlebensdauer [U _R]	2 000 hours at +105°C/+220°F
Gehäuse-Ø [mm]	50 · 75 · 90
Case heights [mm]	Customized from 70 to 100 [typically in 5mm steps]
Case diameters [inch]	1.97 · 2.95 · 3.54
Case heights [inch]	Customized from 2.76 to 3.94 [typically in 0.2inch steps]
External insulation	Lead free PVC sleeve with end disk voltage proof ≥2500 AC
Leakage current [I _L]	≤ 0,008 * C _R [µF] * U _R [V] + 6µA after 5 minutes at U _R
[ESL]	20nH equivalent series inductance
Maximal reverse voltage	2V

Additionally the **MLytic[®] HC + · High Current Power Cap** series features:

4-Pole Technology	Separated inputs and outputs for optimal connection, perfect impulse, no hysteresis losses and exceptional filter characteristics
-------------------	---

*Note: available case diameters
75mm/2.95" and 90mm/3.54"*

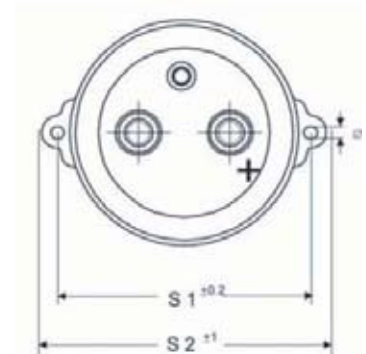
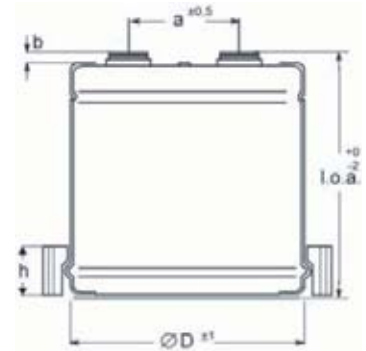

The newest generation of our electrolytic capacitors features a range of distinctive features, which all have one sole objective: **the most authentic music performance possible**. The basic requirement for achieving this goal is the minimisation of unwanted losses [ESR] and inductances [ESL] that occur in the capacitor and affect the signal.

To this end, we have given careful consideration to even the smallest details and have scrutinised and radically reconsidered all existing solutions. You will find the results of our extensive developments below.

The black cathode: The use of special titanium-coated cathode foil has brought about metrologically impressive and tonally spectacular benefits. The matte black polished vacuum-deposited titanium layer thereby substitutes the usual aluminium oxide layer and this then works as an insulator [dielectric] between the aluminium contact foil and the electrolyte, thus forming a second capacitor that negatively influences the overall performance within the capacitor. In this way, the black cathode stops the electrolyte acting simultaneously as a cathode [negative pole] towards the anode foil and as an anode [positive pole] towards the aluminium contact foil.

MUNDORF electrolytic capacitors with black cathodes feature a real cathode foil! This enables extremely fast and almost lossless ion movements, reducing the ESR, distortions and noises it produces itself to an absolute minimum. The positive effects are comparable to when modified electrolytes are used, which are produced for example with the addition of graphite, although the effects of the former are more pronounced. The result is a holographic music playback with a wide and deep on-stage representation and a completely stable focus.

High purity anode foil: Utmost precision during the manufacture and use of high purity materials guarantees a homogeneous etch pattern, as well as a crystalline aluminium oxide layer. Due to this Al_2O_3 layer being the dielectric of the capacitor, it is this balance and precision that also characterises the tone quality of the whole capacitor.

Abaca-esparto paper: The introduction of esparto grass [aka alfa grass] and abaca [also known as Manila hemp or *musa textilis*] into the capacitor paper simultaneously ensures a high mechanical stability and an extremely soft, open structure. The high internal damping of this special paper has a mechanically-appeasing effect on the capacitor and gives the music playback a high degree of neutrality.

Electrolytes: For capacitors of up to 100VDC we only use GBL [also known as butyro-1,4-lactone or *gamma*-butyrolactone], for higher electrical strengths, however, MEG [also known as ethane-1,2-diol or ethylene glycol] is used. The use of this high purity electrolyte, which is chloride-free and largely free from water, considerably improves the long-term stability and thereby also the lifecycle. These electrolytes also feature a low viscosity [that is, a high flow], which has a positive effect on the electrical conductivity. This results in a fast and precise music playback.

Strong together: Thanks to its large surface area, the open structure of abaca-esparto paper possesses an outstanding electrolyte absorption capacity and in combination with its good formability and the outstanding flow of the used electrolytes, guarantees the best possible contact between the electrolyte and the titanium-coated cathode foil. Together, they form the highly-efficient negative pole of the electrolytic capacitor and ensure the smallest possible physical dimensions and optimal performance.

The renouncement of steel: From now on, steel attachments are a thing of the past at MUNDORF! The use of steel as a material for attachments [worldwide standard for snap-ins] brings about a number of disadvantages. Amongst other things, steel attachments cause unwanted eddy currents as a result of their magnetisability, possess a poor electrical conductivity [$\sigma_{25^\circ\text{C}} 6,2\text{MS/m} = 10,7\% \text{ IACS} = 160\text{m}\Omega \cdot \text{mm}^2/\text{m}$] and a low thermal conductivity [$\lambda_{25^\circ\text{C}} 50\text{W}/(\text{m}\cdot\text{K})$]. Furthermore, the high elasticity [200 GPa] and rigidity [7 Mohs] of the steel snap-in claw fasteners put permanent pressure on the soldered joints, which can impair their joining quality.

Highly-conductive contacts: Alongside the familiar, solid aluminium screw terminals [$\sigma_{25^\circ\text{C}} 36,5\text{MS/m} = 63\% \text{ IACS} = 27,5\text{m}\Omega \cdot \text{mm}^2/\text{m} \cdot \lambda_{25^\circ\text{C}} 235\text{W}/(\text{m}\cdot\text{K})$] for the highest currents, all MLYtics® with the most compact design possible possess tin-plated copper attachments [$\sigma_{25^\circ\text{C}} 58,0\text{MS/m} = 100\% \text{ IACS} = 17,2\text{m}\Omega \cdot \text{mm}^2/\text{m} \lambda_{25^\circ\text{C}} 400\text{W}/(\text{m}\cdot\text{K}) 120 \text{ GPA } 3 \text{ Mohs}$]. In order to establish the best possible electrical connection between the individual components, all contacts are welded together.

All of the remarkable technologies mentioned above come together in the new **MLytic®** series to bring about the least losses and maximum high fidelity. Capacitors with **MLytic®** technology: the best MUNDORF electrolytic capacitors of all time!